



# Singh & Company

*Muscat furnace Corner...*



*Reduce Cost*

*Increase Efficiency*

*Guarantee Quality*

*Excellent CraftmanShip*

*Uninterrupted Deliveries*

Annealing  
Induction Melting  
Hard Chrome Plating  
Spring Leaf Manufacturing

Singh & Company is a manufacturing company specializing in cast parts and components such as :

- Pulleys
- Wheel Hubs
- Brake drums
- Aluminum Shafts
- Air Cooled Block
- Connecting Rods
- Crushers Hammer
- Water Pump Routers
- Engine Cylinder Liner
- Industrial engine applications
- Cylinder Liners for automobile



#### Our Certifications

We are ISO 9001:2008, ISO 14000:2004, OHSAS 18001:2007 & API SPEC 4F,6A, 16A, 7-1 certified for manufacturing and marketing operations. We are in this business for past 20 years.

▶▶ The melting process is done by Induction Furnace.

▶▶ Experienced and technically qualified employees to produce highest quality product.

▶▶ Capability to serve customer s demanded quality effectively and efficiently.

▶▶ 100 % Customer satisfaction

▶▶ Guaranteed and assured products

▶▶ High quality machines and high precision testing tools for the inspection.

About Foundry

# Our Activities & Capabilities

- ▶ Grinding
- ▶ Annealing
- ▶ Induction Melting
- ▶ Pattern Shop
- ▶ Core Making
- ▶ Spectrograph
- ▶ Heat Treatment
- ▶ Welding Shop
- ▶ Physical Testing
- ▶ Laboratory Testing
- ▶ Hard Chrome Plating
- ▶ Spring Leave Manufacturing



## INDUCTING MELTING

We cast various kind of automotive components:

- Axle parts
- Crushing plants
- Hammers
- Beaters
- Cement Plant balls



Blow bars in different grades like manganese, chromium, light tensile non wear parts as per customers requirement and design.

- Homogenization of the melt due to stirring of the melt
- Less oxidation losses (dross) because no local overheating
- High accurate alloying process
- High quality of the melt even with cheap charge material (scrap)
  - High throughput because fast melting and fast heating up of the melt
  - High furnace efficiency
  - Simple handling of the furnace and the process
    - Well defined controlling of the power input
    - Good working conditions for the workers at the furnace
    - Environmental friendly (small dust emission, no exhaust gas)
    - Well defined melt temperature
      - Simple automatic process control

Our Products & Services

## Heat Treatment & Hard Chrome Plating

To improve further the quality of heat Treated components we have setup in house modern heat treatment shop having controlled atmosphere furnace such as :



- Normalizing.
- Carbonitriding Rotary Retort Furnace.
- Gas Carburizing Vertical Pit type furnace.
- Forced Air Circulation Tempering Furnace.

## ANNEALING MELTING

Our Annealing process, which removes stress from the steel, is critical to insure the core will deliver optimum accuracy and minimum excitation loss. Achieving a flawless annealing process is an art which requires a precise combination of temperature, time and atmosphere.

*“ We are committed to the highest standards of excellence in every thing we do”*

**Our Products & Services**

# PRODUCTS & FACILITES

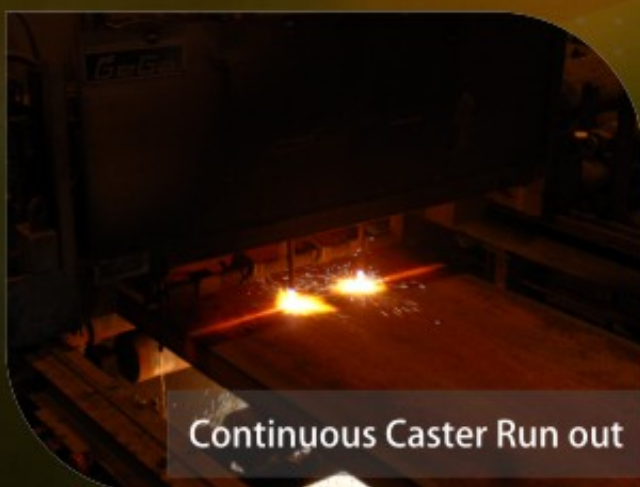

# PRODUCTS & FACILITES



Induction Furnace



Walking Beam Furnace



Induction Melting Furnace



Induction Furnace



Wear Resistant Hammer



Crusher Hammer



Crusher Hammer



Cast Gears & Drums

## SPRING LEAF MANUFACTURING

Singh & Company is having years of experience in the industry, We has gained the much required proficiency to guide you in your selection of the appropriate leaf springs for your vehicle. you will find it all at Singh & Company, at quite affordable prices. Plays a vital role as a consistent quality products manufacturer and supplier since its inception.

- Singh & Co uses the latest manufacturing technology available to achieve the highest Quality Standards.



- A leaf spring can be made from several leaves stacked upon each other in several layers.

- Singh & Co manufactures Multi leaf Springs ranging from 3Kg to 200 Kg.

- Our latest technology not only improves the life of the product but also ensures high level of consistency in the each product.



Walking Beam Furnace

We design and build a special set of leaf springs that will improve the ride, handling and stance.

Leading Technology..  
Innovative designs..



Our Products & Services

## SPRING LEAF PROCESS

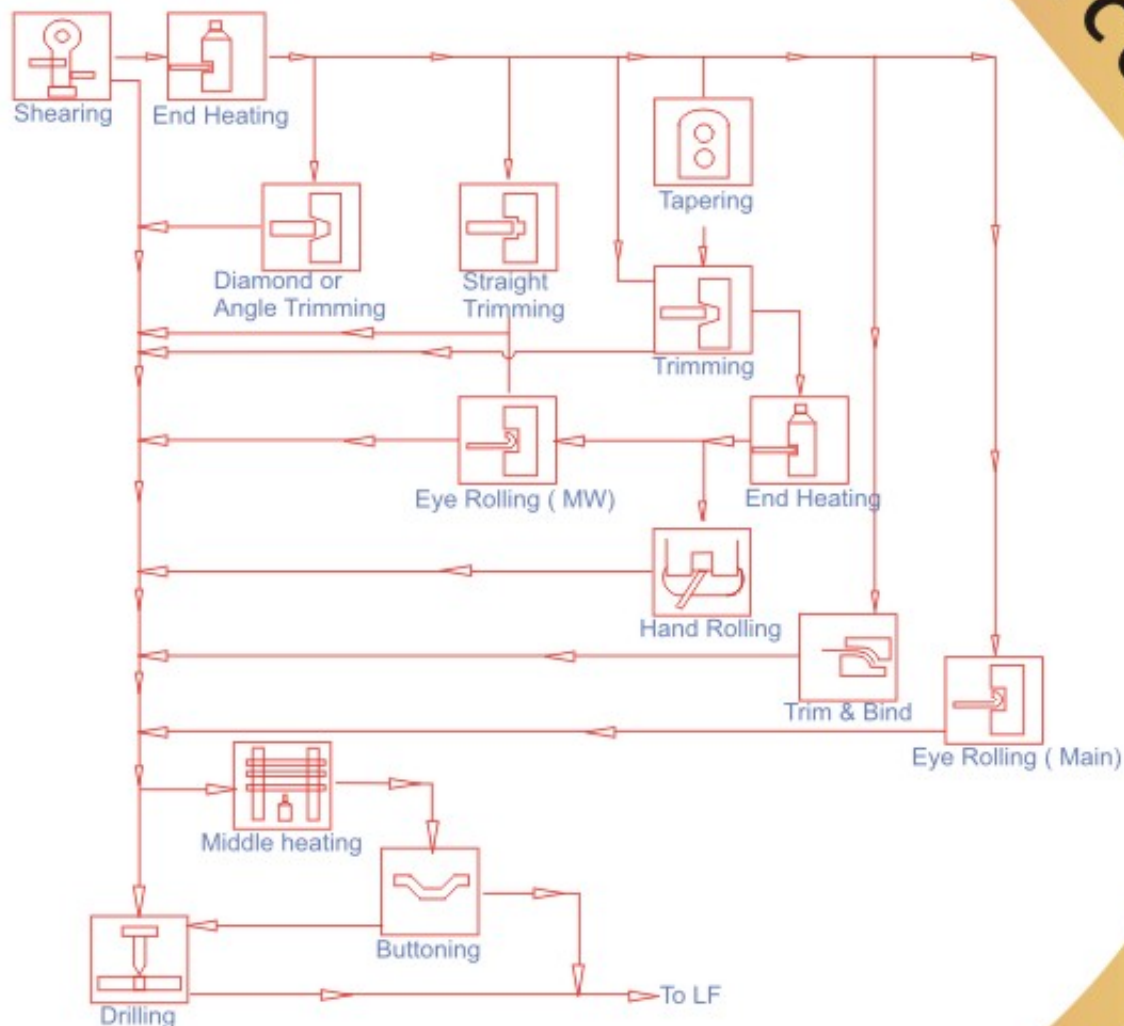

# LABORATORY & TESTING

## Metals & Alloys

- Wide range of Certified reference materials (CRM)
- Analyze by direct emission spectrometer, XRF or ICP Spectrometer
- Ferrous Metals & Non Ferrous Metals are tested.

## Test Services

Physical Tests : Tensile Strength, Bend, Dimensions, Flaring, Hardness, Impact Strength, Corrosion Resistance, Non Destructive Test, Internal Defects, Wall Thickness, Decarburization, Coating thickness & Surface defects.

## Mechanical Testing

- Tension tests (at high/ low temp.)
- Compression, transverse
- Hardness Tests
- Impact Tests
- Shear tests
- Bend tests



## Metallography

- Effective Case Depth
- Depth Of Surface Defect
- Non-metallic Inclusion Content
- Macroscopic Examination
- Depth Of Cladding
- Micro Hardness Image Analysis
- Grain Size

## Non- Destructive Testing

- X-ray Radiography
- Magnetic Particle Testing
- Ultrasonic Testing
- Radiography
- Portable Hardness
- Thickness Survey
- Visual Tests

Laboratory & Testing

**QUALITY,**  
**HEALTH,**  
**SAFETY &**  
**ENVIRONMENT**

Singh & Co as a Casting company in service sector in the Sultanate of Oman is much committed to the highest standards for Quality, Health, safety & Environment (QHSE) throughout its operation and to achieve the same we have implemented a comprehensive and integrated Quality Health & Safety Management system.

**QHSE objectives**

- Provide safe & healthy working atmosphere
- Achieve zero Lost Time Injury
- Protect the environment from any sort of harm
- Attain preparedness to manage any sort of emergency
- Maintain and continuously improve system to ensure the safety of people and assets
- To promote sustainable development

Singh & Co practice 4R concept, Reduce, Reuse, Recycle and Replace as the basic principle of waste minimization. We got certification of OHSAS 18001, an international health and safety management system and also have ISO 14001 standard, a globally recognized benchmark for excellence in eco-management.

Being an ISO 9001-2000 certified Company; we have a well defined quality control process that is structured to meet customer satisfaction on the benchmark of Quality. We strive to achieve a consolidated, sustained and independent growth that reinforces long term business relation with our satisfied clients.

Health, Safety & Environment



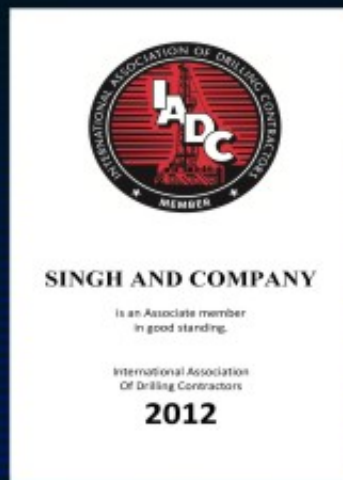

P.O.Box 2138 P.C.111, CPO Seeb, Muscat, Sultanate of Oman Website : [www.singhandco.com](http://www.singhandco.com)  
 Tel : 00968-24-501705/06 Fax : 00968-24-593937 Email : [casting@singhandco.com](mailto:casting@singhandco.com)